

Gearbox for engine endurance tests

T-shape gearbox / Vertical offset / 1600 Nm @ 12 000 rpm

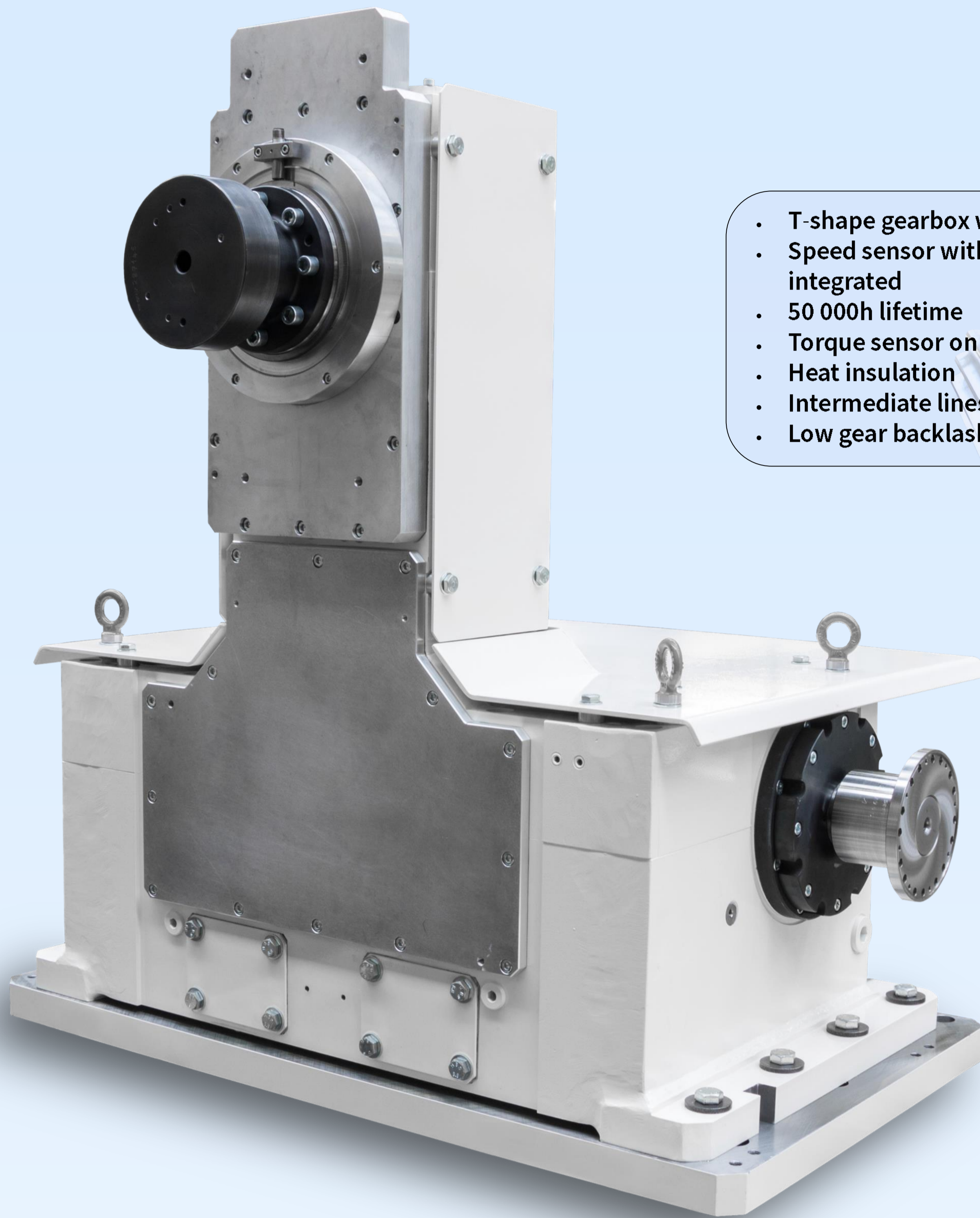

- T-shape gearbox with vertical offset
- Speed sensor with phonic wheel integrated
- 50 000h lifetime
- Torque sensor on HS side
- Heat insulation
- Intermediate lines on freewheels
- Low gear backlash

Power
Input Speed
Output Speed
HS Maximum Torque
Weight

2 x 375 kW
12 000 rpm
7 850 rpm
1 600 Nm
1 100 kg

Puissance
Vitesse d'entrée
Vitesse de sortie
Couple maximum GV
Poids

KR 5817



Gearbox for engine endurance tests
Réducteur pour validation et essai d'endurance moteur

SP 900 T8 2I

www.bcsagear.fr

ISO 9001:2015
BUREAU VERITAS
Certification

